

David A. Borengasser
6/10/18

SCS
STEWART CONSULTING SERVICES
CIVIL ENGINEERS | PLANNERS | CONSTRUCTION MGMT.
TBPE FIRM F-17175
P.O. BOX 82
HUMBLE, TX 77347
PH: (713)446-8537
FAX: (281)858-2335
www.stewartconsultingservices.com

17211 PAD SITE
17211 IH45
HOUSTON, HARRIS CO., TX 77090

PROJECT:

REV	ISSUE DATE	DESCRIPTION
0	06/04/2018	ISSUED FOR PERMIT/BID

SHEET TITLE:
SWQMP DETAILS

PRJ NAME: 17211 PAD SITE
DATE: JUNE 03, 2018
SHEET NO: **C4.2**

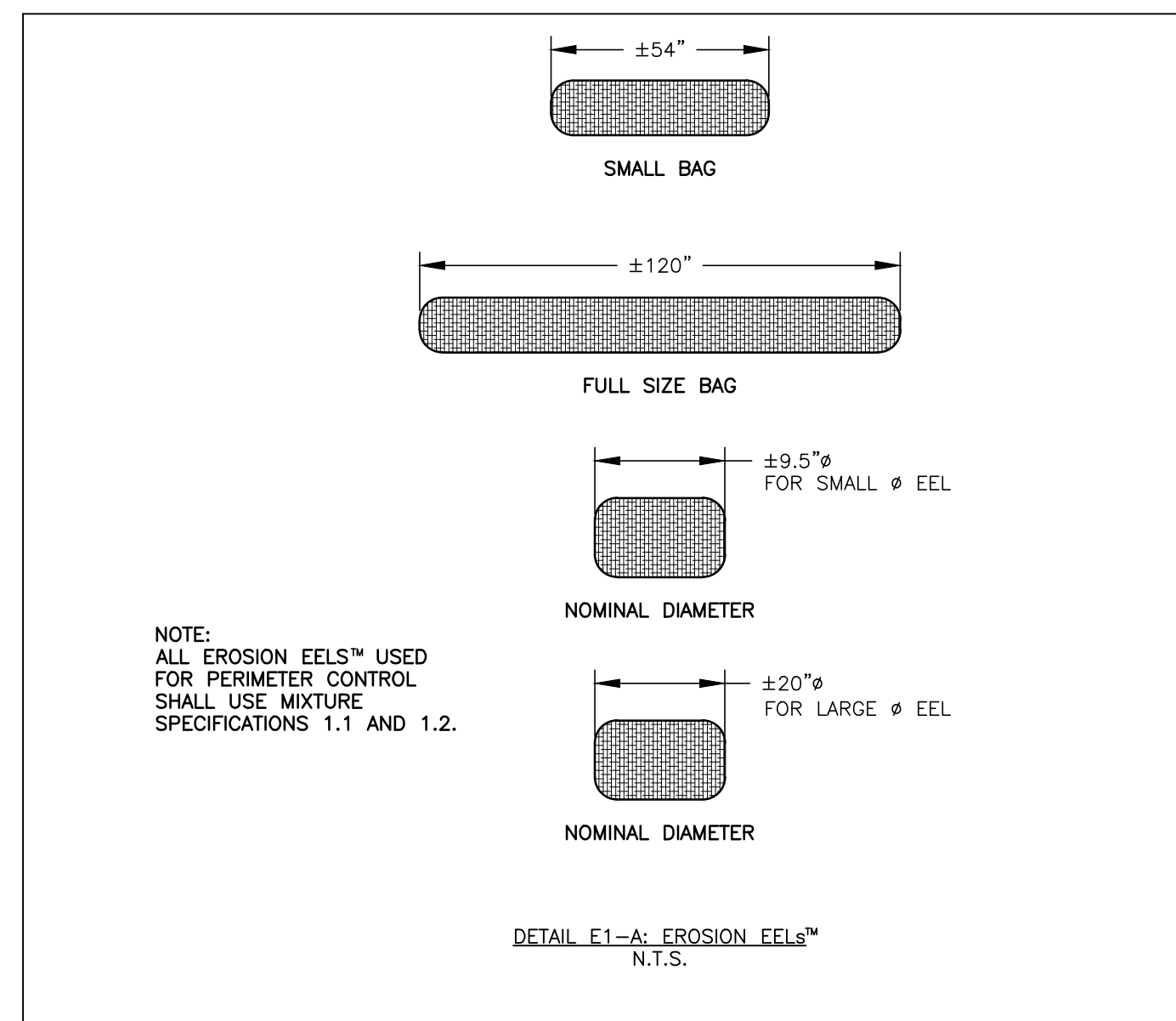
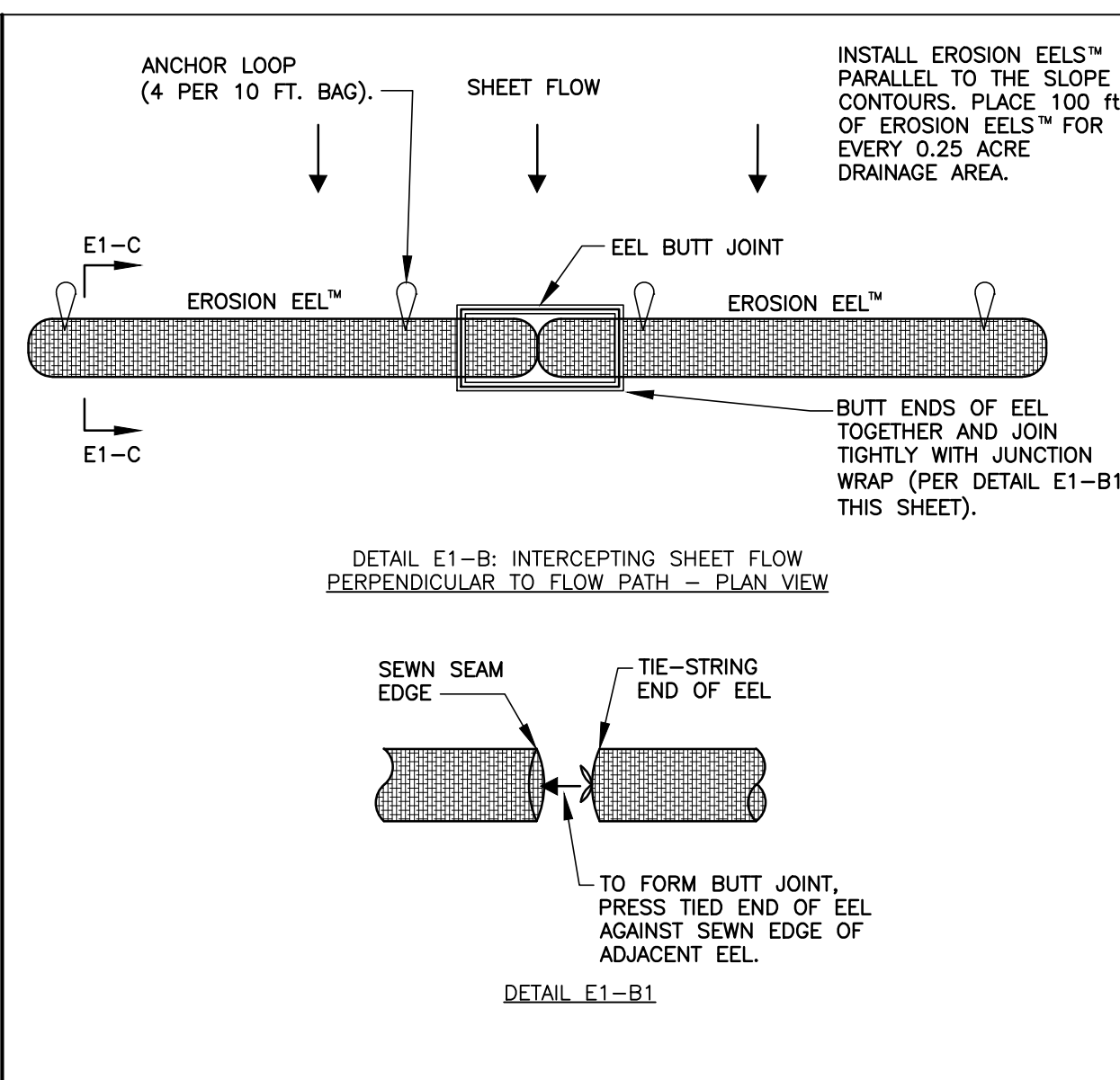
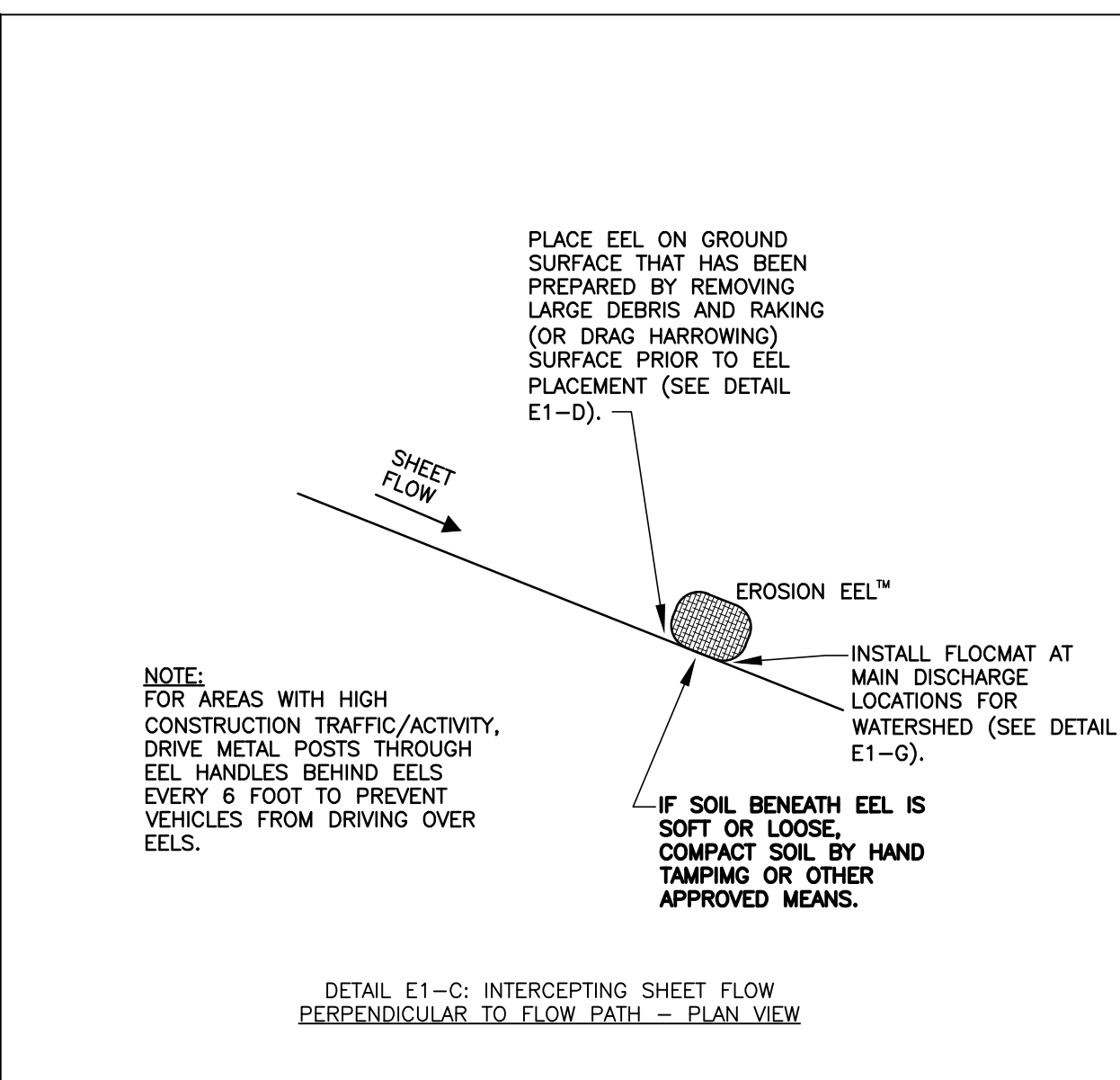
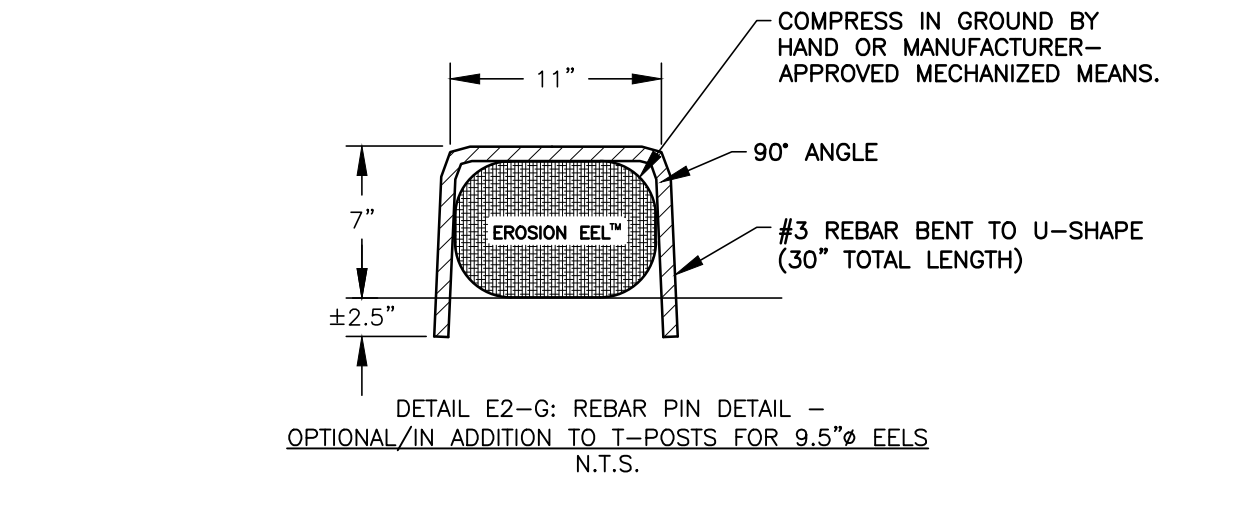
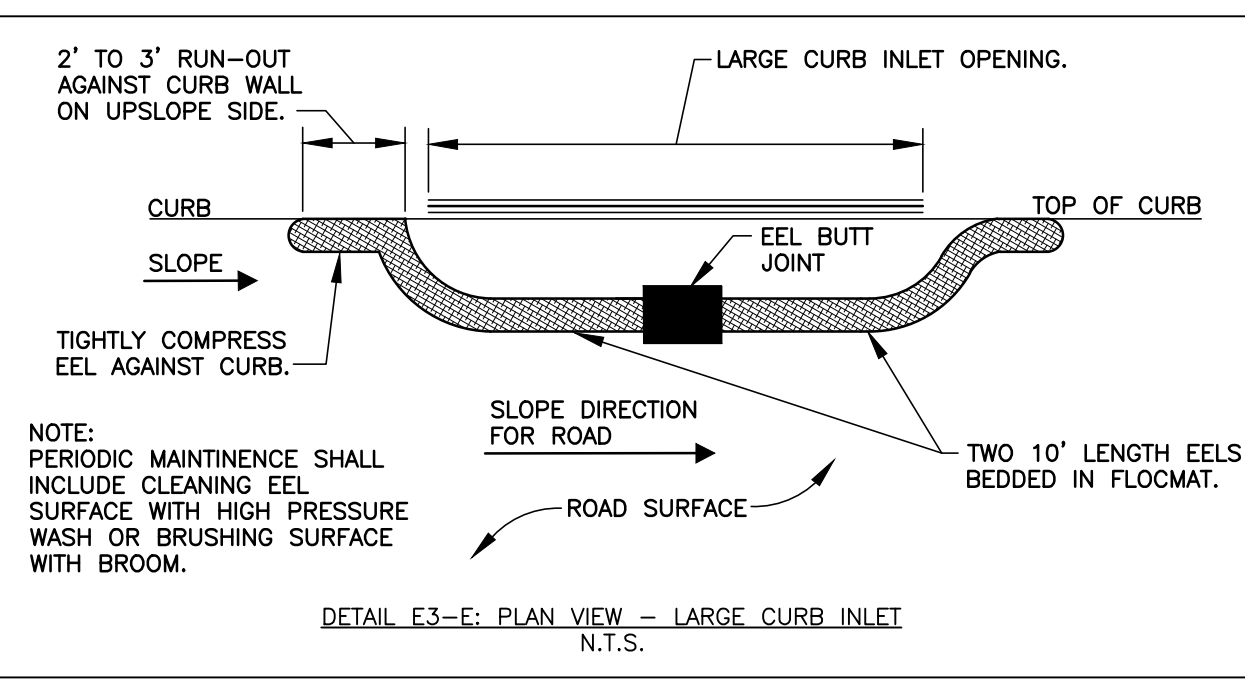

- GENERAL NOTES:
1. EROSION EELS™ USED IN PERIMETER CONTROL APPLICATIONS SHALL HAVE A SPECIFICATION MIXTURE 1.1 OR 1.2.
 - a. MIXTURE SPECIFICATION 1.1. A FILTER MIXTURE COMPRISED OF 50% SHREDDED RUBBER AND 50% WOOD CHIP PARTICLES BY VOLUME. THE SHREDDED RUBBER SHALL BE WASHED AND PROCESSED TO REMOVE MOST, IF NOT ALL, METAL COMPONENTS. THE RUBBER SHALL BE DERIVED FROM RECYCLED TIRES AND SHALL BE SHREDDED TO PRODUCE A MAXIMUM PARTICLE SIZE OF +/- 3/4 INCH. THE WOOD CHIPS SHALL BE PRODUCED FROM HARDWOOD TREES AND SHALL CONFORM TO AASHTO CERTIFICATION SPECIFICATION MP 9-03.
 - b. MIXTURE SPECIFICATION 1.2. A FILTER MIXTURE COMPRISED OF 1/3 SHREDDED RUBBER, 1/3 WOOD CHIPS, AND 1/3 RECYCLED SYNTHETIC FIBERS. THE SHREDDED RUBBER SHALL BE WASHED AND PROCESSED TO REMOVE MOST, IF NOT ALL, METAL COMPONENTS. THE RUBBER SHALL BE DERIVED FROM RECYCLED TIRES AND SHALL BE SHREDDED TO PRODUCE A MAXIMUM PARTICLE SIZE OF +/- 3/4 INCH. THE WOOD CHIPS SHALL BE PRODUCED FROM HARDWOOD TREES AND SHALL CONFORM TO AASHTO CERTIFICATION SPECIFICATION MP 9-03. THE SYNTHETIC FIBERS SHALL BE PRODUCED FROM RECYCLED, MANUFACTURED MATERIALS, SUCH AS, BUT NOT LIMITED TO, PRE-CONSUMER SCRAP CARPET, TIRE CHORD, AND TIRE FIBER MATERIALS.
 2. EROSION EELS™ SHALL BE MANUFACTURED FROM A WOVEN GEOTEXTILE COVERING WITH INTERIOR FILTER MATERIALS SUCH AS 100% SHREDDED RUBBER (MIXTURE SPECIFICATION 1.0, 50% SHREDDED RUBBER/50% AASHTO-CERTIFIED WOOD CHIPS (MIXTURE SPECIFICATION 1.1)).
 3. LENGTHS OF EROSION EELS™ SHALL BE EITHER A NOMINAL +/-10 FT. OR +/- 4.5 FT. NOMINAL DIAMETER SHALL BE +/-9.5 INCHES.
 4. EROSION EELS™ CAN BE PLACED AT THE TOP, ON THE FACE, OR AT THE TOE OF SLOPES TO INTERCEPT RUNOFF, REDUCE FLOW VELOCITY, RELEASE THE RUNOFF AS SHEET FLOW AND PROVIDE REMOVAL OF SEDIMENT FROM THE RUNOFF.
 5. EROSION EELS™ SHALL BE INSTALLED ALONG THE GROUND CONTOUR, AT THE TOE OF SLOPES, AT AN ANGLE TO THE CONTOUR TO DIRECT FLOW AS A DIVERSION BERM, AROUND INLET STRUCTURES, IN A DITCH AS A CHECK DAM TO HELP REDUCE SUSPENDED SOLIDS LOADING AND RETAIN SEDIMENT, OR AS A GENERAL FILTER FOR ANY DISTURBED SOIL AREA.
 6. NO TRENCHING IS REQUIRED FOR INSTALLATION OF EROSION EELS™
 7. PREPARE BED FOR EEL INSTALLATION BY REMOVING ANY LARGE DEBRIS INCLUDING ROCKS, SOIL CLODS, AND WOODY VEGETATION. EROSION EELS™ CAN ALSO BE PLACED OVER PAVED SURFACES INCLUDING CONCRETE AND ASPHALT WITH NO SURFACE PREPARATION REQUIRED.
 8. RAKE BED AREA WITH A HAND RAKE OR BY DRAG HARROW.
 9. DO NOT PLACE EEL DIRECTLY OVER RILL AND GULLIES UNTIL AREA HAS BEEN HAND-EXCAVATED AND RAKED TO PROVIDE A LEVEL BEDDING SURFACE. ALL SURFACES SHALL BE UNIFORMLY COMPACTED FOR MAXIMUM SEATING OF EELS IN PLACE.
 10. FOR LOCATIONS WHERE EELS WILL BE PLACED IN CONCENTRATED FLOWS (SUCH AS CHECK DAMS, INLET PROTECTION) AND FOR PERIMETER CONTROLS AT PRIMARY DISCHARGE LOCATIONS, BED THE EELS IN A FLOCMAT CRADLE PER THE DETAILED DRAWINGS.
 11. FOR DITCH APPLICATIONS, THE MAXIMUM DRAINAGE AREA SHALL BE 10 ACRES.
 12. IF MORE THAN ONE EROSION EEL™ IS PLACED IN A ROW, THE EELS SHALL BE OVERLAPPED A MINIMUM OF 12 INCHES TO PREVENT FLOW AND SEDIMENT FROM PASSING THROUGH THE FIELD JOINT. COMPRESS THE TWO EELS OF THE OVERLAP TIGHTLY TOGETHER EITHER BY HAND OR MANUFACTURER-APPROVED MECHANIZED MEANS.
 13. WHEN USED IN DITCHES AS A CHECK DAM, EROSION EELS™ SHALL BE INSTALLED PER MANUFACTURER'S DETAILS.
 14. FOR CHECK DAM APPLICATIONS, EROSION EELS™ SHALL BE PLACED PERPENDICULAR TO THE FLOW OF THE WATER. EROSION EELS™ SHALL CONTINUE UP THE SIDES SLOPES A MINIMUM OF 3 FEET ABOVE THE DESIGN FLOW DEPTH.
 15. EROSION EELS™ SHALL REMAIN IN PLACE UNTIL FULLY ESTABLISHED VEGETATION HAS COMPLETELY DEVELOPED OR UNTIL THE STORAGE CAPACITY/FUNCTIONAL LIFE OF THE EEL HAS BEEN EXHAUSTED (REQUIRING REPLACEMENT WITH NEW EELS).
 16. ANCHORING POSTS FOR CHECK DAM APPLICATIONS SHALL HAVE A MINIMUM WEIGHT OF 1.25 LBS/FT STEEL T-POSTS (5 TO 7 FT. LENGTHS) ROLLED FROM HIGH CARBON STEEL. POSTS SHOULD BE HOT-DIP GALVANIZED OR COATED WITH A WEATHER-RESISTANT PAINT FOR STEEL APPLICATION. POSTS SHOULD BE EQUIPPED WITH A METAL ANCHOR PLATE. INSTALL PER DETAILS ON THIS SHEET.
 17. PLACE T-POSTS THROUGH HANDLE OF BAGS. DO NOT DRIVE POSTS THROUGH EROSION EELS™. T-POSTS ARE TO BE EMBEDDED A MINIMUM OF 2 FT INTO GROUND.

