

PLEASE RECYCLE

6

5

4

3

2

1

G

F

E

D

C

B

A

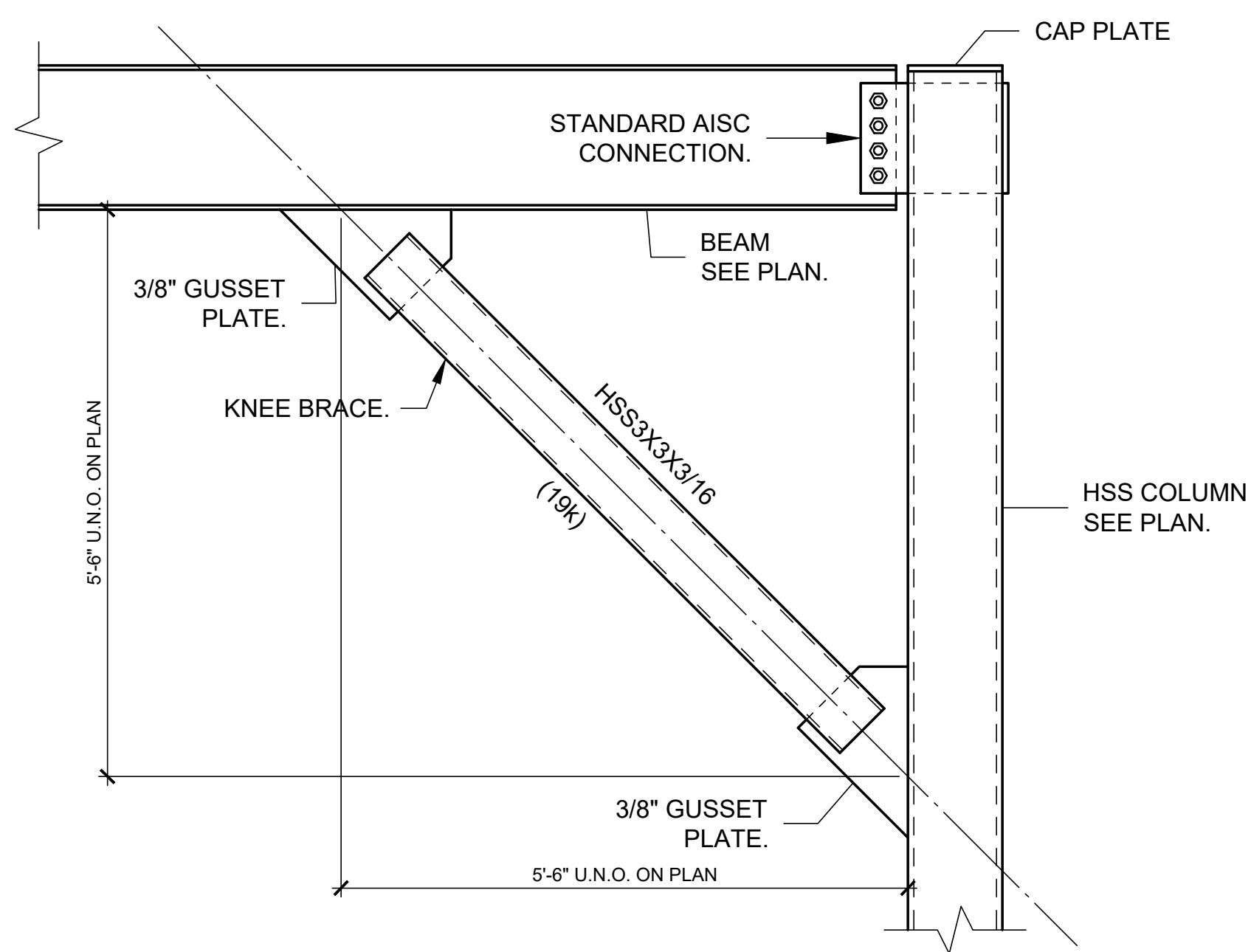

5 KNEE BRACE DETAIL

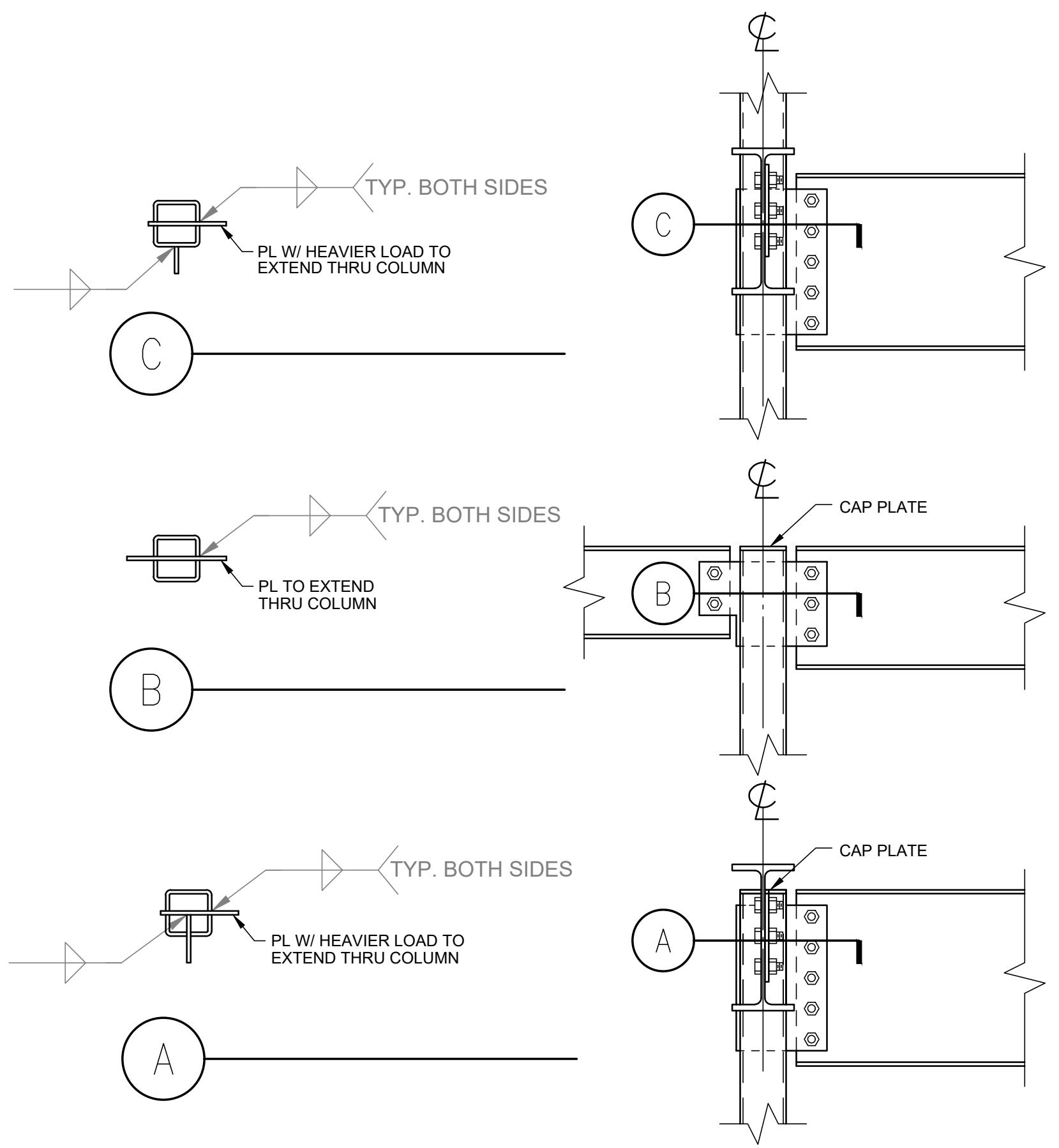

4 TYPICAL STEEL CONNECTIONS

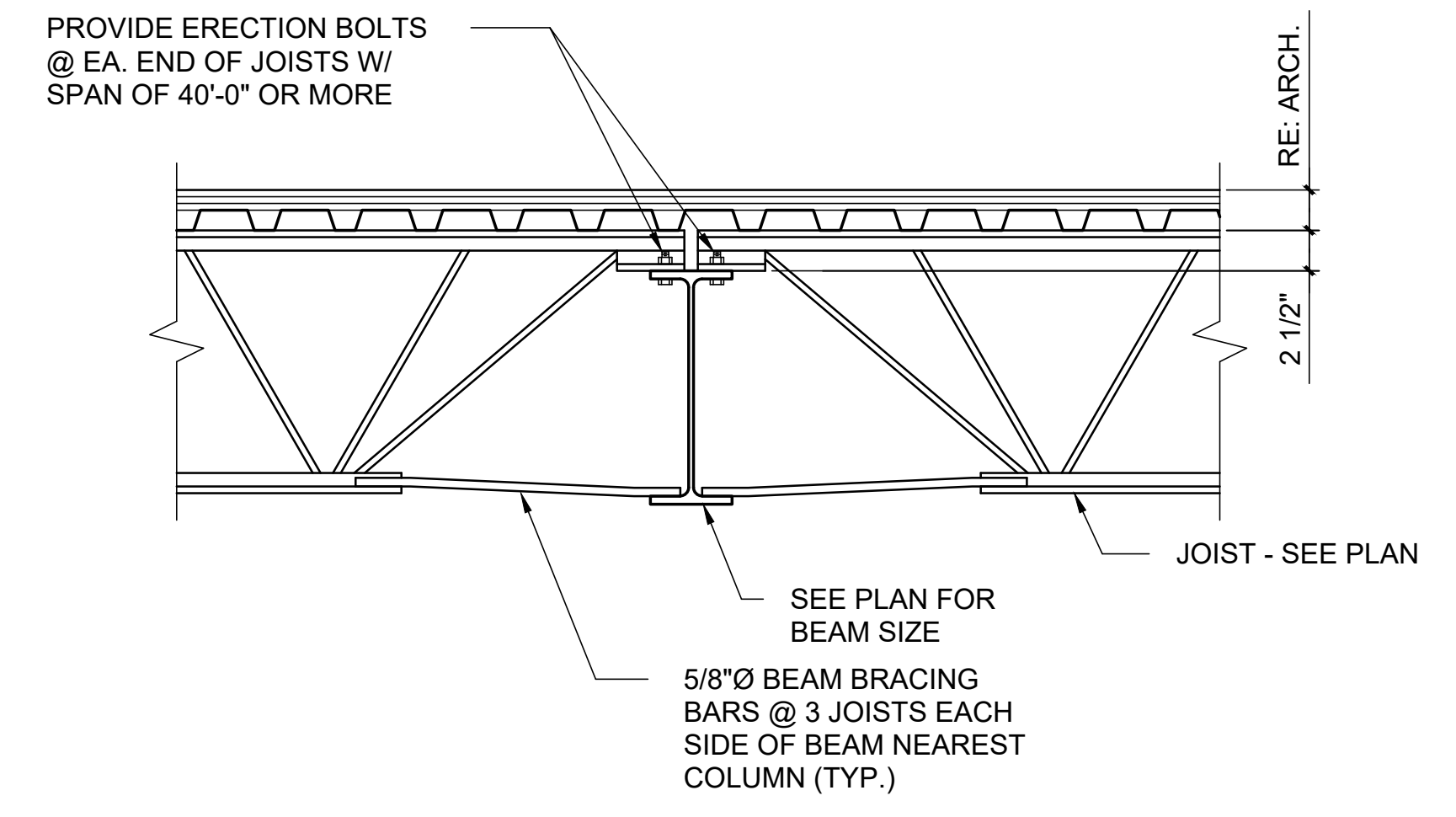

3 INTERIOR JOIST BEARING

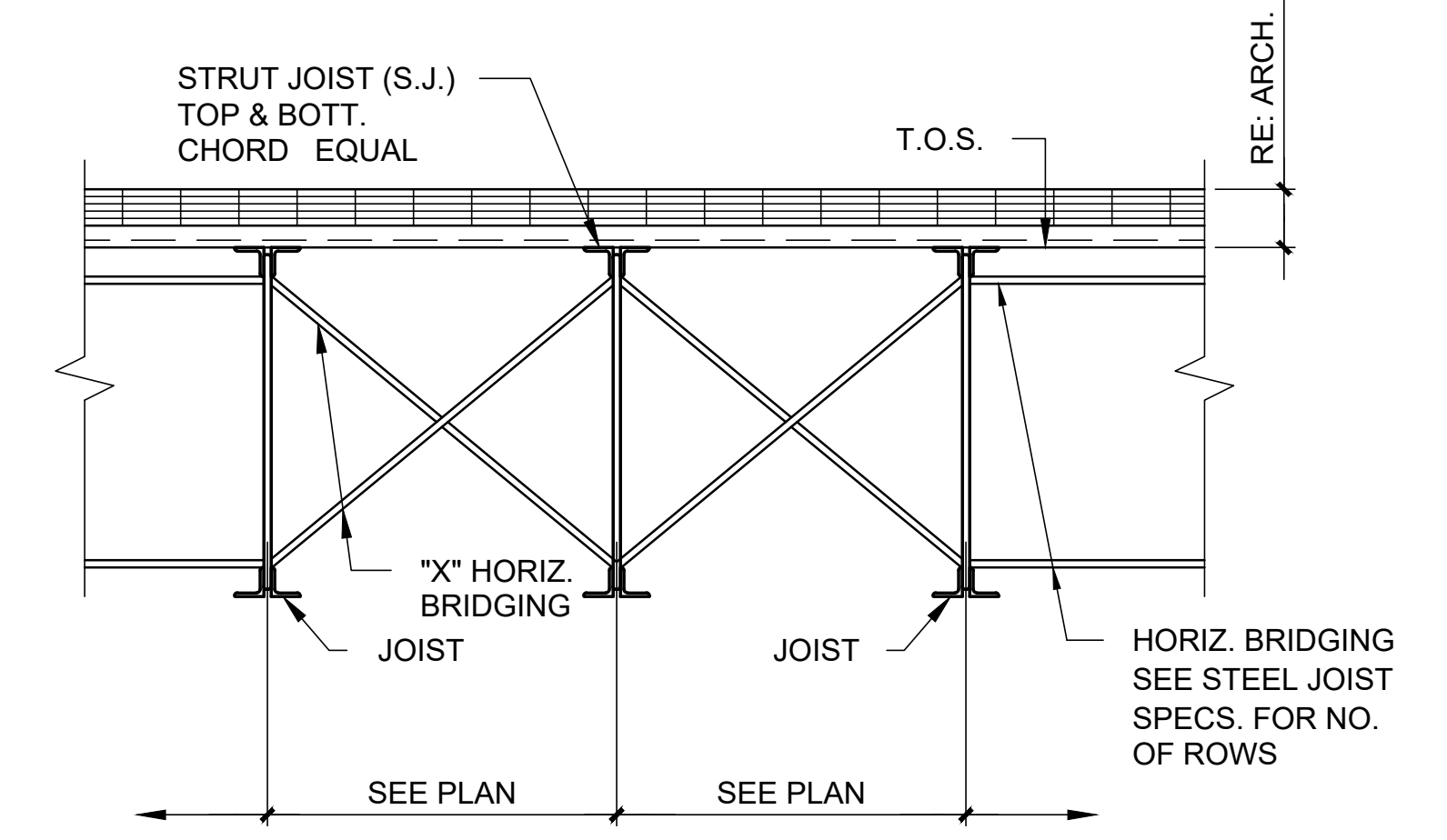

2 BRIDGING AT STRUT JOIST

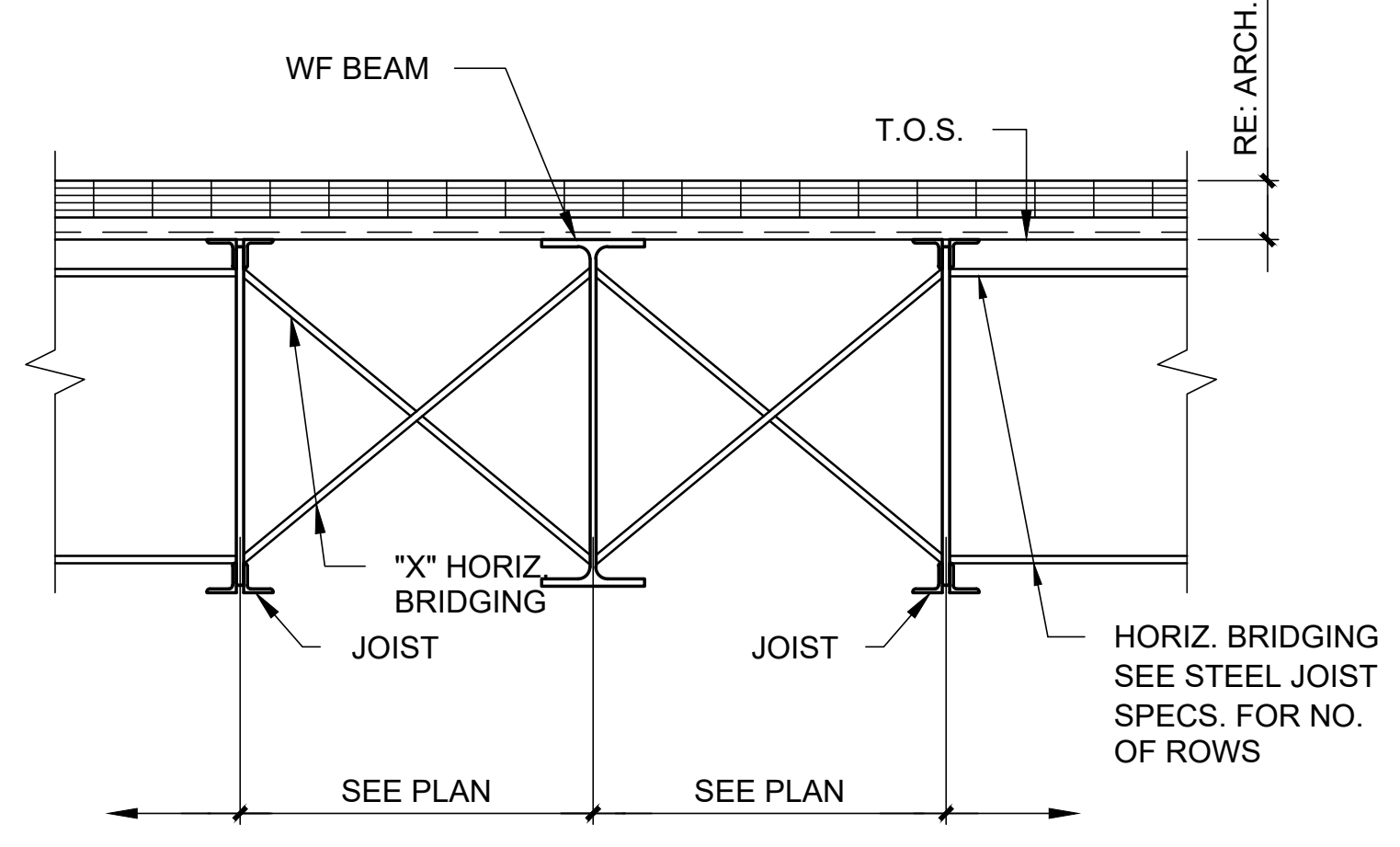

1 BRIDGING AT WF BEAM

ISSUE/REVISION	
ISSUE FOR PERMIT & PRICING	
DATE	06/13/2018
NO.	
WWW.BIGREDDOG.COM	
TEXAS REG. NO. F-11201	



832.431.4560

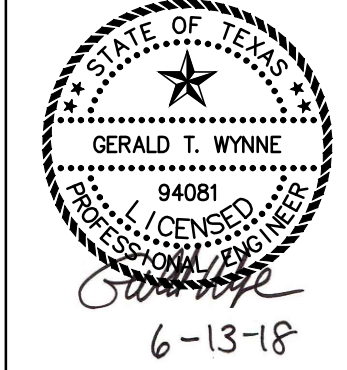

PROJECT: 17211 PAD SITE
17211 145 SOUTH - Houston, TX 77090

SHEET TITLE: Framing Details

S402

SCALE: 1" = 1'-0"

G

F

E

D

C

B

A

DRAWING NAME: XXXX © 11-18 8:22AM Tom Rodriguez